



Blue Carbon
 蓝晶易碳

BCT-SPC

Power Can



PV Energy Storage Commercial Lighting System (PVESCLS)

BCT

Product Introduction



- Handle
- Master switch
- AC output
- DC output
- USB output
- Louver
- Voltage display

Application Places

Widely used in business places, home, factories, workshops, suitable for home lighting, commercial lighting, fieldwork, night markets lighting, factory workshops, etc. For no electricity area, it could be charged by solar panel in daytime, and lighting in the night. For the areas that city power is expensive, it can be charged during the electricity valley value period, and used at the peak power period. Can be used as backup power, totally replace of commercial lighting, industrial lighting, and all kinds of emergency lighting, used as mobile generator.

- No need electricity bill
- Energy saving
- Easy installation
- Long life span

Blue Carbon, no need electricity bill at all.



Advantages

- Compact design, small size, convenient to carry.
- Power Can, High quality cold-steel mould, anti-corrosion, longer life, Integrated design, beautiful and practical.
- Using LiFePO₄ battery, the life span is more than 12 years.
- Integrated packing, easy transportation.

Technical Parameters

USB output	Two circuits output 5V/2A
DC output	Six circuits DC output 12V
Battery electric	LiFePO ₄ battery 1kW-h
Product size	408×309×126mm
Maximum power that can be worked at the same time	500W
Solar panel	12V/180W (Mono-crystalline)
Optional products	Common 10W LED×2
	Common 20W LED×1

Optional Products

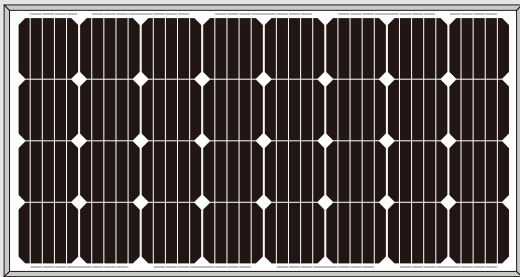

180W Solar Panel

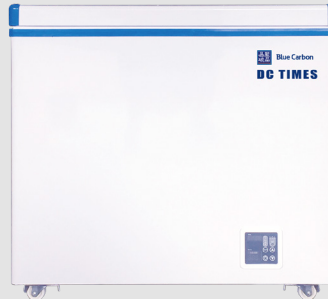

99L DC Freezer



DC Fan



20W Flood Light ×1



10W Flood Light ×2



DC TV





Blue Carbon
蓝晶易碳

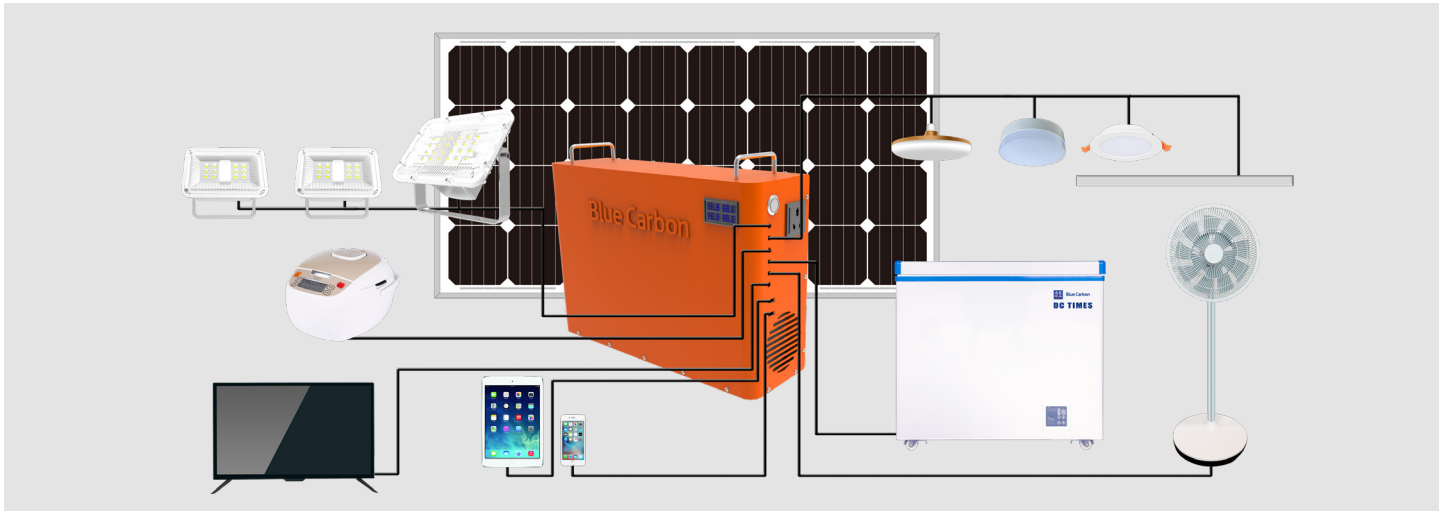

Product Size

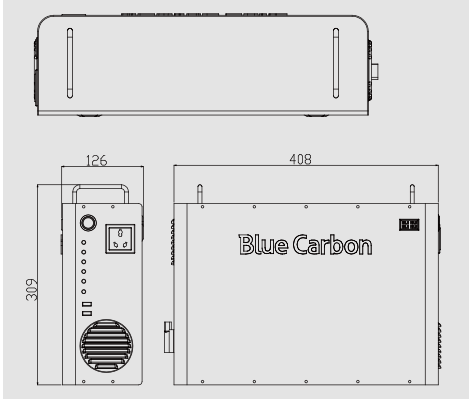

External Lamp (Flood Light)

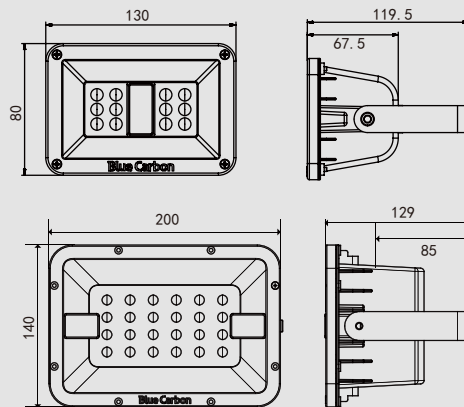

Solar Panel

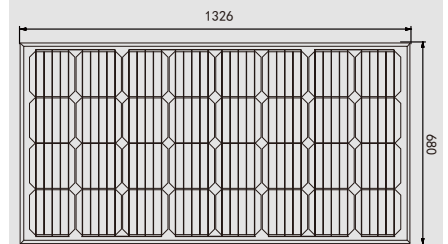

Instructions

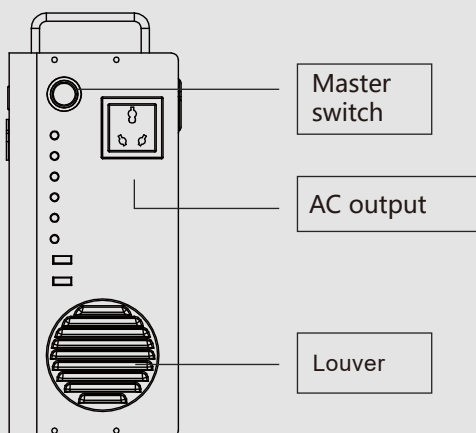

Attention:

1. Press the master switch, then the power Can will start work, when not use, please turn off the master switch, to avoid because of long time no use waste result in add other equipments not have good function.
2. Power Can can be used both with 12V DC appliances and small power AC appliances after connected with 12V inverter(less than 100W appliances are suggested).
3. Apply for any 12V DC equipments(better use the suggested 12V equipments).
4. We do not suggest adding any inverter to add the AC equipments.
5. It is prohibited to put the Power Can outdoor during rainy days.
6. It is prohibited to disassemble or repair by none professional persons.



Tel: +86-0633-2190373
E-mail: sales@bluecarbontech.com

www.bluecarbontech.com



Blue Carbon
蓝晶易碳

BCT

Application Places



Home power

PV Energy Storage Commercial
Lighting System

Power Can

Market Lighting



Household electricity



Night work



Exhibition hall



Emergency charger



Tel: +86-0633-2190373
E-mail: sales@bluecarbontech.com

www.bluecarbontech.com